

REDFOOT

LEVELLING

FIAT Ducato - Alko Chassis Bracket Installation

Part Numbers FID-ALKO-HI-SL and FID-ALKO-LO-SL



Front bracket kit assembly:

1x RF-P-0022-03 Front Passenger side mounting bracket

1x RF-P-0026-04 Front Drivers side mounting bracket

2x RF-P-0023-02 Clamp Plate

2x Clamping Bar

2x Pivot T-Piece

4x M10 100mm Socket Head Screw bolts

4x M10 30mm bolts

4x Spring washers

2x M10 Dual Rivsert Paddle Sticks

2x M10 25mm Countersunk Socket Head Screw bolts

4x M10 Nyloc Nuts and washers

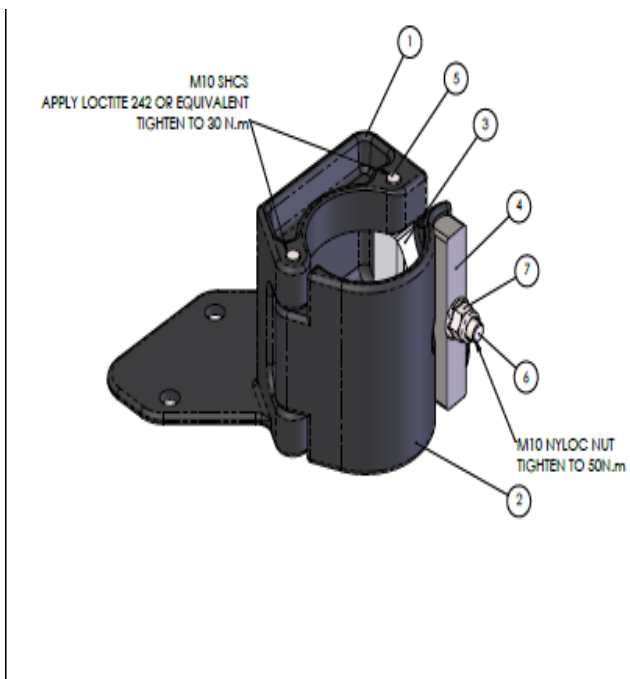

ITEM NO.	PART NUMBER	DESCRIPTION	QTY.
1	RF-P-0022-03	CLAMP BRACKET	1
2	RF-P-0023-02	CLAMP PLATE	1
3	RF-P-0024-02	STEEL PIVOT T-PIECE	1
4	RF-P-0025-01	STEEL CLAMPING BAR	1
5	DIN 912 M10 x 100 — 32N	SHCS M10 x 100	2
6	DIN 976-2 — MFS M10 x 65 — N	STUD BOLT M10 x 65	1
7	DIN EN 1663 - M10 - N	M10 NYLOC NUT	1

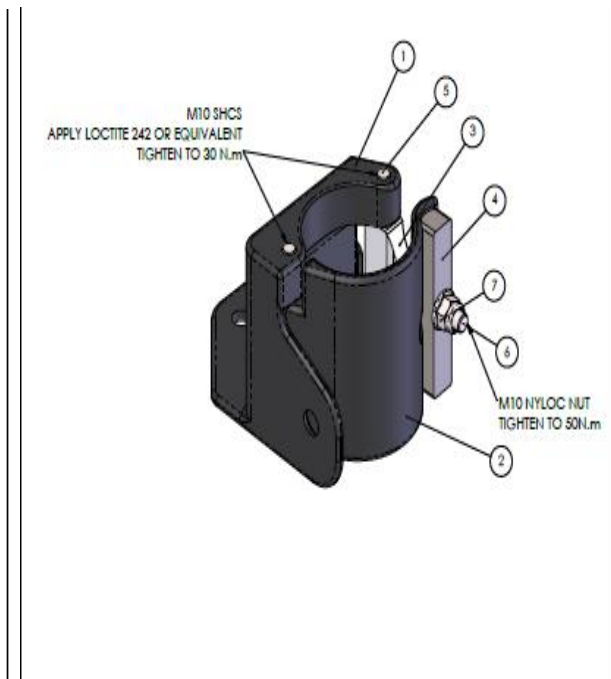

ITEM NO.	PART NUMBER	DESCRIPTION	QTY.
1	RF-P-0026-04	CLAMP BRACKET	1
2	RF-P-0023-02	CLAMP PLATE	1
3	RF-P-0024-02	STEEL PIVOT T-PIECE	1
4	RF-P-0025-01	STEEL CLAMPING BAR	1
5	DIN 912 M10 x 100 — 32N	SHCS M10 x 100	2
6	DIN 976-2 — MFS M10 x 65 — N	STUD BOLT M10 x 65	1
7	DIN EN 1663 - M10 - N	M10 NYLOC NUT	1

*Typically the rear cylinders will not require additional mounting brackets for the Alko chassis. If mounting the cylinders outside the chassis cannot be achieved then 'optional' mounting brackets can be supplied for mounting inside the chassis rail. Read the Rear Cylinder locations section below for clarification.

OPTIONAL (Inside chassis mount) Rear bracket kit assembly will include: 1x Part No. BRI-ALK – PAIR of inside chassis mounting brackets, 8x ½" Bolts, 8x ½" Bolts and Nuts

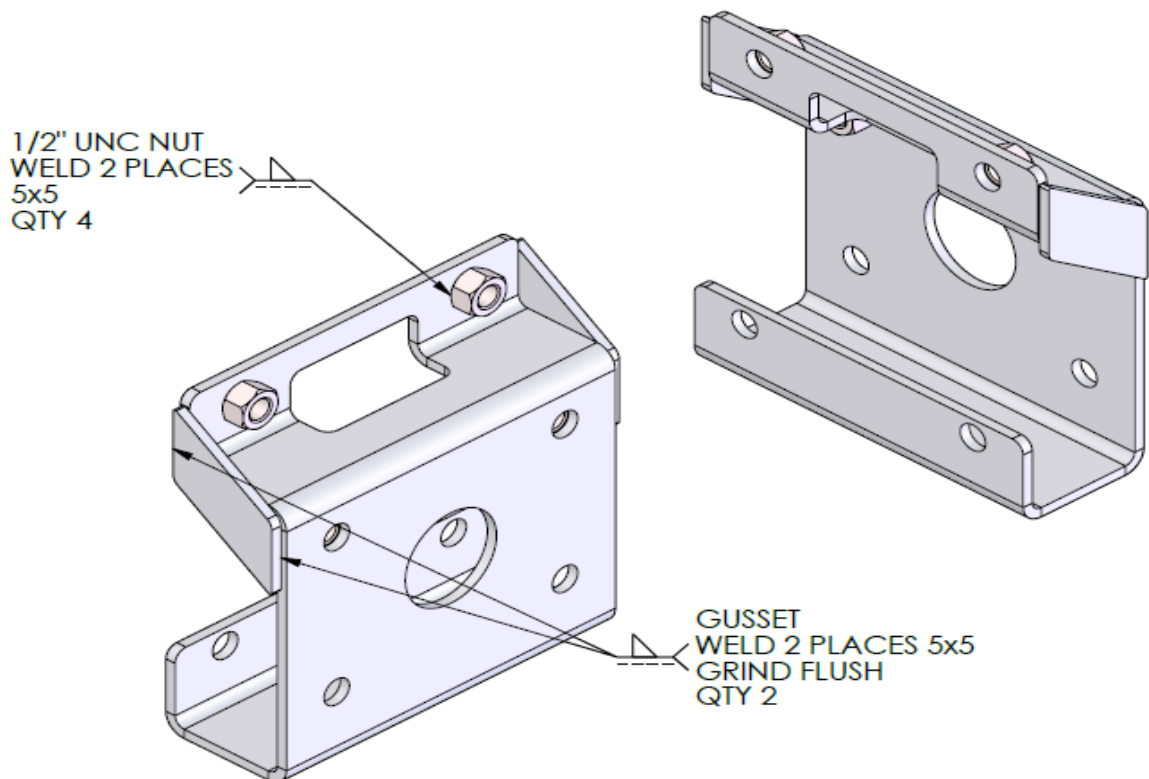

Tools Required:

Power Drill (Ideally a Right Angle Drill)

Impact Wrench or Rattle Gun

10.5mm drill bit

Torque Wrench

16mm Socket and Spanner

18mm Socket and Spanner

¾" Socket and Spanner

1-1/16" Socket and Spanner

8mm Hex Socket head screw

6mm Allen key

****IMPORTANT!** Each cylinder foot plate are to be mounted using the 1-1/16" locking nut supplied. A rattle gun or impact wrench must be used when tightening or loosening the locking nut.

REDFOOT Front Passenger side location

Front passenger side mounting bracket assembly



MOUNTING BRACKET INSTRUCTIONS

1. The front passenger side bracket location is inside the chassis rail directly behind the passenger seat and between the vehicles battery box and fuel tank.
2. Firstly, clear away and reposition any existing looms and cables as shown.
3. With your bracket glue into position with the 6mm spacer between the chassis and bracket and use a spirit level to make sure it is straight and mark with a paint pen the 3 holes for drilling both underneath and inside the chassis as shown.
4. Using a 10.5mm drill bit, drill the 3 holes as required. A small right angle drill will be advantages for drilling into these tight spacers.
5. Remove the square bung/plug located underneath the chassis. This will give you an access point into the chassis.
6. Insert the two holed Rivsert Paddle Stick into chassis plug hole as shown and align with the drilled two holes underneath the chassis rail. You will need to bend the handle as shown.
7. Hold the mounting bracket to the chassis and align holes, insert 2x M10 x 30mm bolts provided and lightly tighten. You will need to hold the paddle stick also, so a second pair of hands will be required for this process.
8. Once in place insert the countersunk M10 40mm Socket Head Screw bolt into the side, place the M10 Nyloc nut and washer behind and tighten using a 6mm Allen key to 30nm. Then tighten the two M10 x 30mm to 25nm.

Front passenger side bracket mounting location and spacer

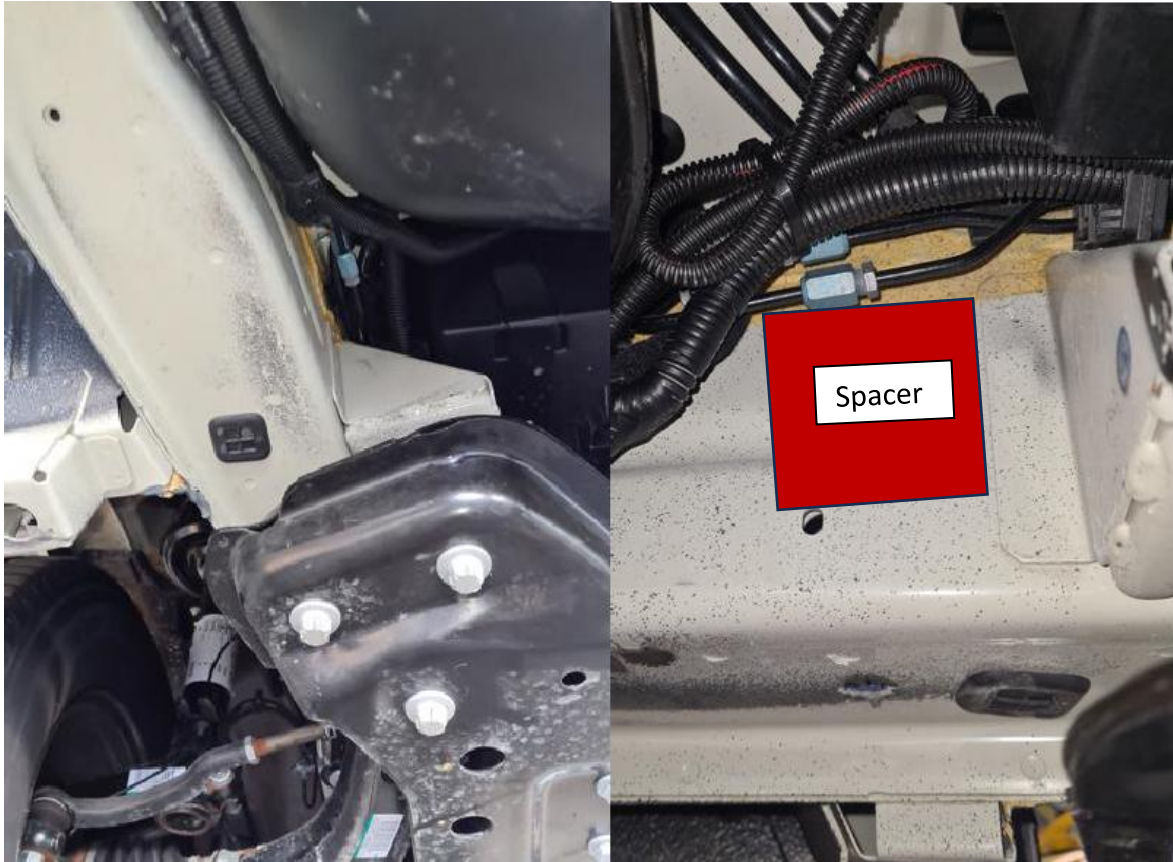

Mark the hole positions with paint pen

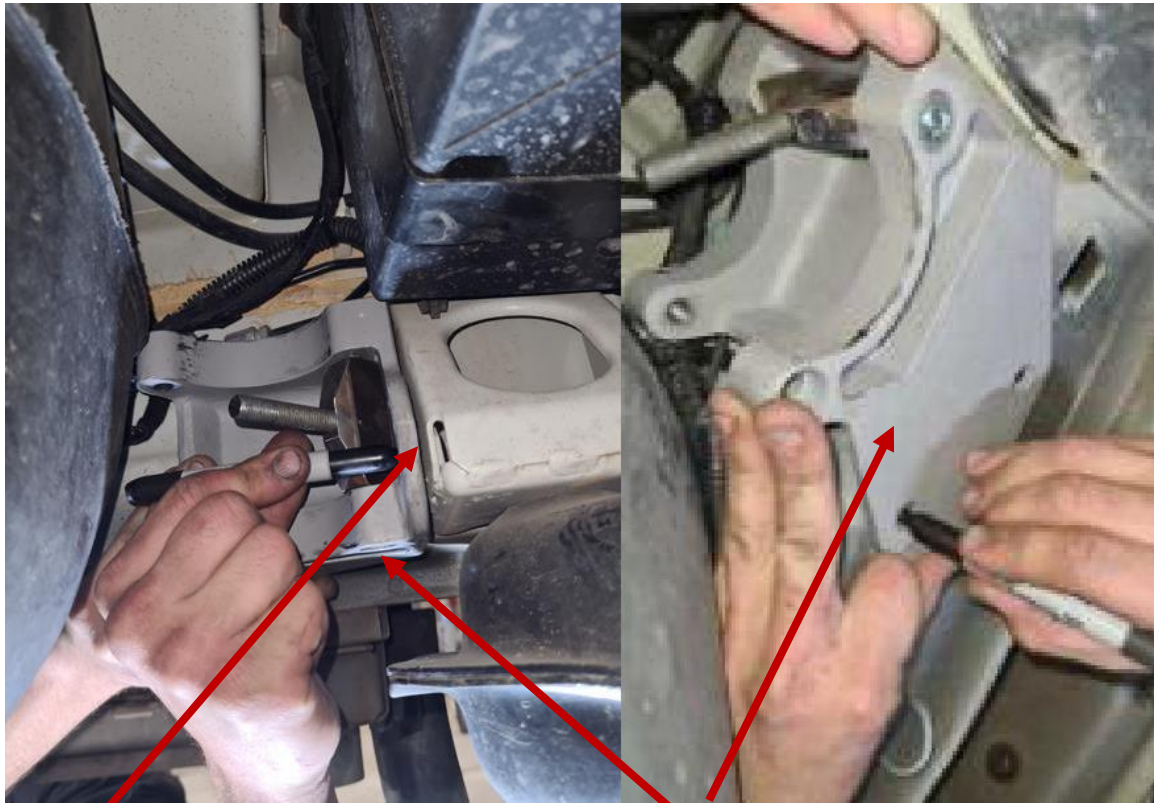

Make sure this surface is flush

Use spirit level on this surface

Drill through chassis as marked

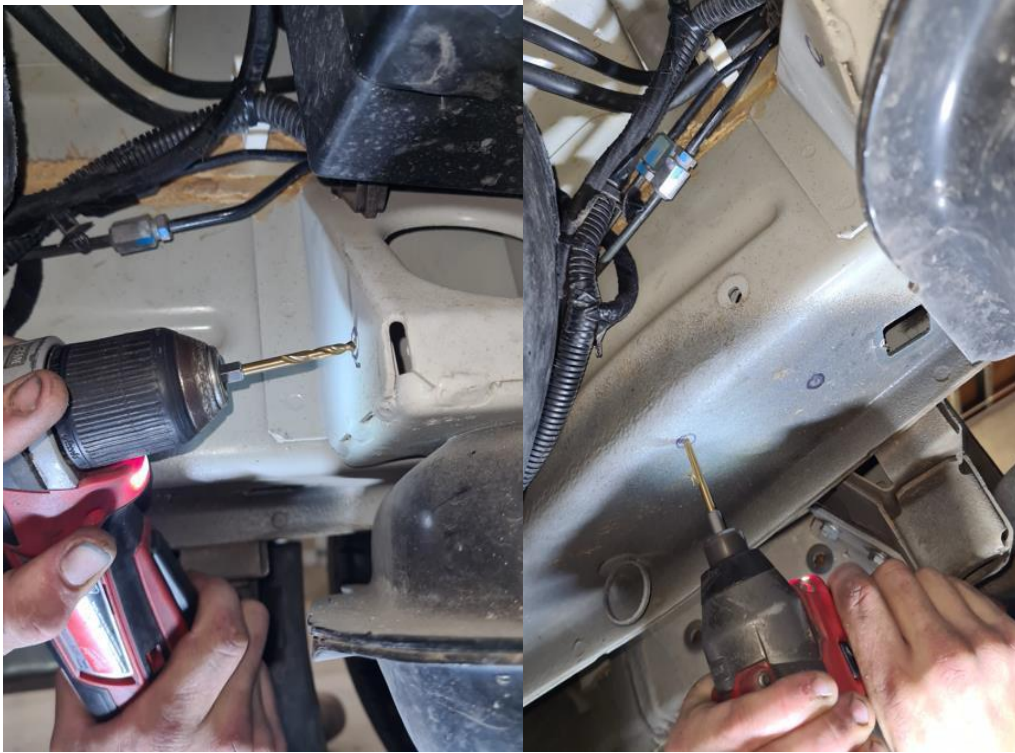

Inserting nut plate with bolts and tightening

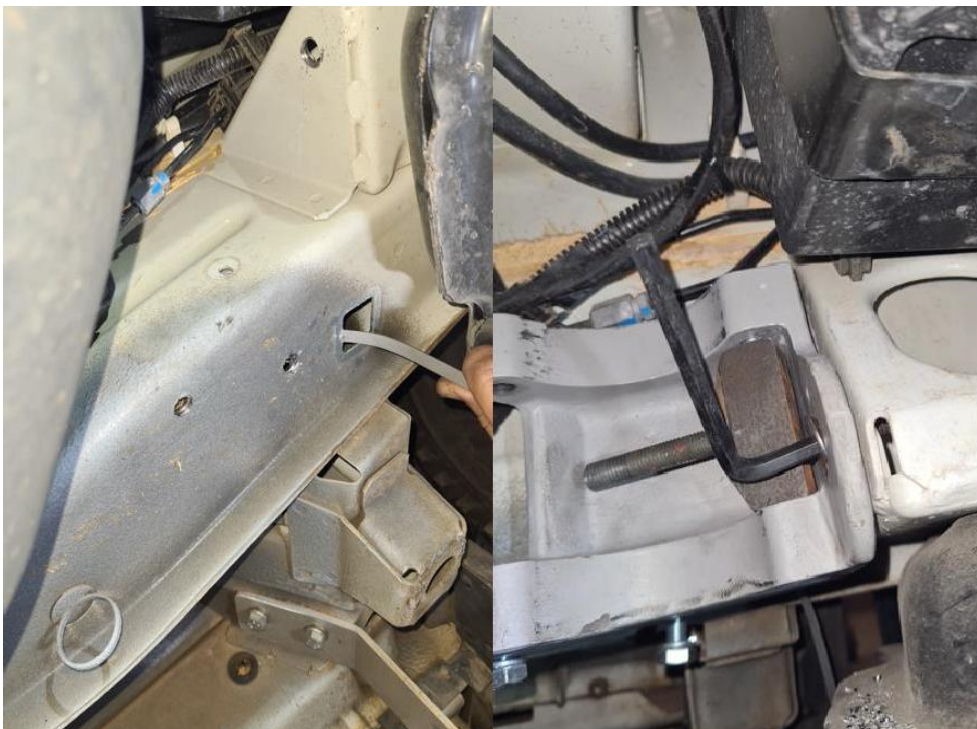

MOUNTING HYDRUALIC CYLINDER INSTRUCTIONS

9. Once the bracket has been affixed to the chassis the cylinder can be place into position as shown. Make sure the distance from bracket to bottom of cylinder is the same on both left and right cylinders. Use the Clamp Plate provided that wraps around the outer cylinder and align the hole both on the Clamp Plate and bracket. When this has been achieved insert the M10 100mm bolt and tighten. (use torque wrench to tighten at 30Nm)
10. The cylinder is now held freely in place and can be lifted or turned 360 degrees into the correct position prior to tightening the Clamp Plate. The optimal height from bottom of cylinder to ground in 200mm. Ensure you face the top port fitting towards the adjacent chassis rail as shown. This will allow easy fitment on hydraulic hose later.
11. Insert the Clamping Bar over the exposed Pivot T-Piece bolt on the bracket as shown and use the Nyloc nut to tighten loosely. Once you have the cylinder in the optimal position tighten the M10 Nyloc Nut at 50Nm using a torque wrench.
12. Once this has been achieve you can now install the foot plate to the underside of cylinder using the 27mm locking nut provided.
13. **IMPORTANT!!** When tighten the foot plate to cylinder ensure to only use a rattle gun or impact wrench.

Tightened all bolts and position your cylinder



Hold the cylinder in place and use the Clamp Plate to align with the bracket holes, insert the M10 100mm Socket Head Screw bolt as shown.

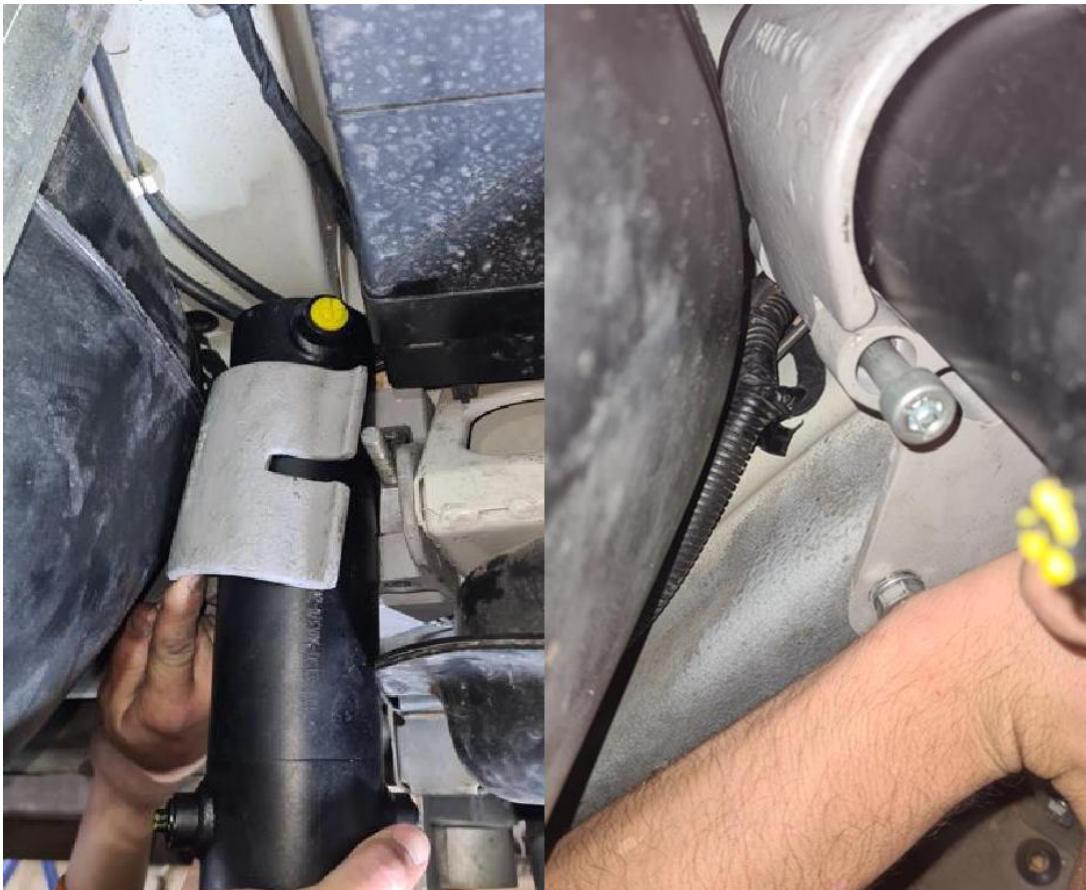

Tighten the M10 100mm Socket Head Screw bolt at 30Nm with Torque wrench.

This will hold cylinder loosely in place without dislodging. Place the Clamping Bar over the existing T-Piece Pivot bolt as shown and attach the M10 Nyloc nut.



Adjust the cylinder to correct height from the ground and tighten the M10 Nyloc nut to 50Nm



REDFOOT Front Driver side location

Front driver side mounting bracket assembly

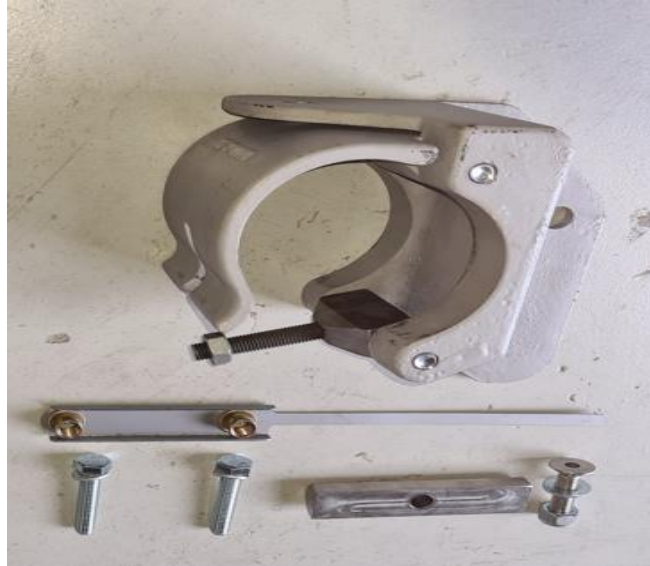

MOUNTING BRACKET INSTRUCTIONS

14. The front driver side bracket location is inside the chassis rail directly behind the underfloor of the driver seat and close to exhaust and catalytic converter.
15. Firstly, to clear this area on some vehicles you will be required to cut and remove some of the heat shield as shown.
16. With your bracket glue into position with the 6mm spacer between the chassis and bracket and use a spirit level to make sure it is straight and mark with a paint pen the 3 holes for drilling both underneath and inside the chassis as shown.
17. Using a 10.5mm drill bit, drill the 3 holes as required. A small right angle drill will be advantages for drilling into these tight spacers.
18. Remove the square bung/plug located underneath the chassis. This will give you an access point into the chassis.
19. Insert the two holed Rivsert Paddle Stick into chassis plug hole as shown and align with the drilled two holes underneath the chassis rail. You will need to bend the handle as shown.
20. Hold the mounting bracket to the chassis and align holes, insert 2x M10 60mm bolts provided and lightly tighten. You will need to hold the Rivsert Paddle Stick also, so will a second pair of hands would be required for this process.
21. Once in place insert the countersunk M10 40mm Socket Head Screw bolt into the side, place the M10 Nyloc nut and washer behind and tighten using a 6mm Allen key. Then tighten the two M10 x 30mm to 25nm.

Cut and remove heat shield if required and place spacer



Mark the hole positions with paint pen while using a spirit level



Use spirit level on this surface



Make sure and bracket and this surface is flush

Drill through chassis as marked



Inserting nut plate with bolts and tightening



MOUNTING HYDRUALIC CYLINDER INSTRUCTIONS

22. Once the bracket has been affixed to the chassis the cylinder can be place into position as shown. Make sure the distance from bracket to bottom of cylinder is the same on both left and right cylinders.
23. The cylinder can now be lifted or turned 360 degrees into the correct position prior to tightening the Clamp Plate. The optimal height from bottom of cylinder to ground in 200mm. Ensure you face the top port fitting towards the rear of vehicle or parallel to the chassis rail as shown. This will allow easy fitment on hydraulic hose later.
24. Now insert the Clamping Bar over the exposed Pivot T-Piece bolt on the bracket as shown and use the Nyloc Nut to tighten loosely. Once you have the cylinder in the optimal position tighten the M10 Nyloc Nut at 50Nm using a torque wrench.
25. Once this has been achieve you can now install the foot plate to the underside of cylinder using the 27mm locking nut provided.
26. **IMPORTANT!!** When tighten the foot plate to cylinder ensure to only use a rattle gun or impact wrench.

Tightened all bolts and position your cylinder



Place the Clamping Bar over the existing pivot bolt as shown and attach the M10 Nyloc nut.



Adjust the cylinder to correct height from the ground and tighten Nyloc nut at 50Nm using a Torque Wrench



REDFOOT Rear Cylinder locations

Rear location is outside chassis within 1m behind rear axle
Serrated flanged hardware must be torqued to 86Nm (63lb-ft).

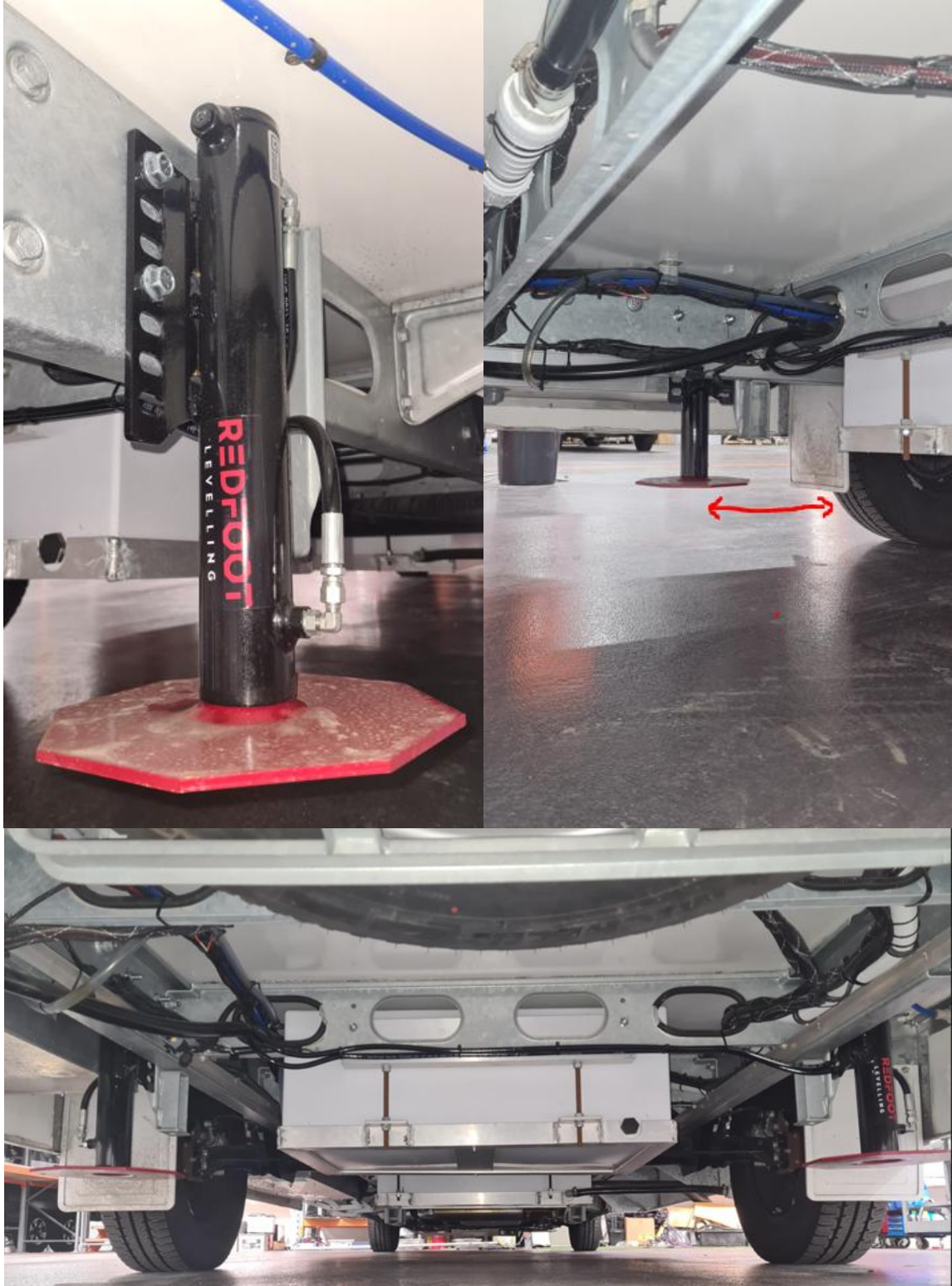

Mounting Rear Cylinders to chassis

1. Typically the Rear cylinders don't require additional mounting brackets. The location for these rear cylinders are to be mounted flat against the outside chassis rail, within 100cm behind the rear axle. Finding free real estate in this area is key. If this cannot be achieved due to storage bins, exhaust or other obstructions you may require additional inside chassis mounting brackets (Part No.BRI-ALK) as found in the OPTIONAL Bracket section.
2. The Cylinder flat plate holes are designed to affix flush to the outside of the Alko Chassis rail as shown. When affixing Cylinders to chassis you must mount to main chassis rail, not to any extensions or any sub-frames.
3. Position the Cylinder onto the chassis rail and mark with paint pen a minimum of 4 holes. Try and space out these holes as far apart as vertically possible. Try and use the most bottom hole when marking.
4. When marking ensure the bottom of the cylinder is approx. 200mm from the ground.
5. Drill 4x 13mm holes as marked
6. Hold cylinder and align holes. Insert the ½" bolts through the 4 outside Cylinder mounting plate holes and chassis rail. Use the Nuts supplied and tighten.
7. Once this has been achieved you can now install the foot plate to the underside of cylinder using the ¾" locking nut.
8. **IMPORTANT!!** When tighten the foot plate to cylinder ensure to only use a

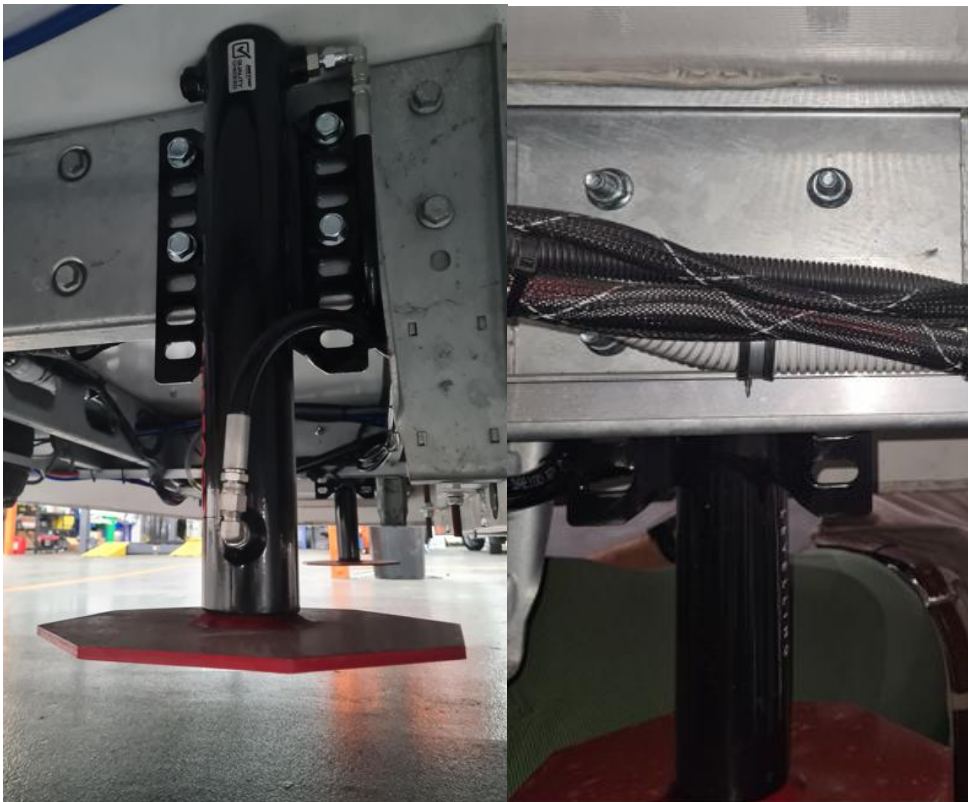

OPTIONAL Inside Chassis Mount Rear Brackets (Part No. BRI-ALK)

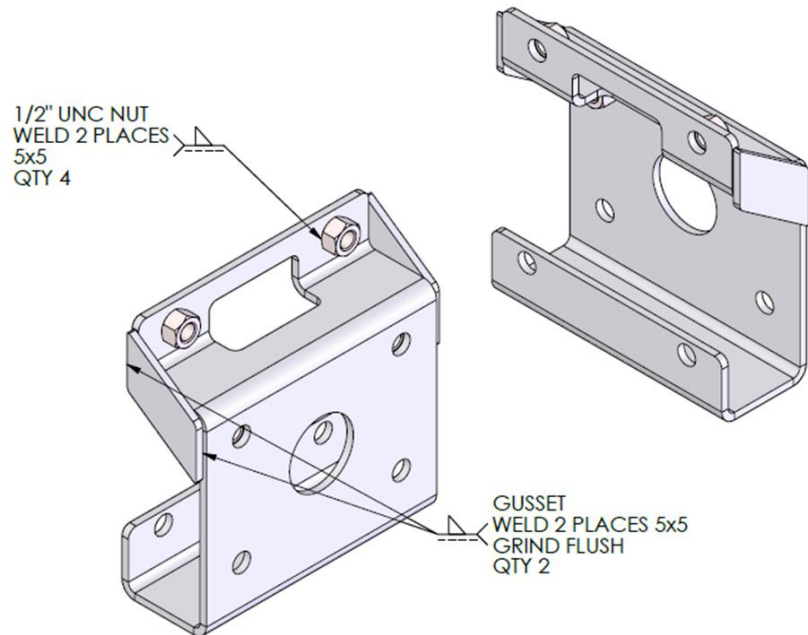

9. The location for the rear brackets is to be mounted flat against the inside of the chassis rail, within 100cm behind the rear axle. Finding free real estate in this area is key.
10. The rear brackets will have 4 holes to be used to mark your holes. 2 holes will sit flush inside towards the top of chassis and 2 more holes outside towards the chassis as shown. Once in position mark with a paint pen. When affixing brackets to chassis you must mount to main chassis rail, not to any extensions or any sub-frames.
11. Drill 4x 13mm holes as marked
12. Align holes and affix bracket into position. Once in position insert the ½" bolts through the top two outside holes, these will screw into the rivert on back of mounting bracket. Then insert the bottom bolts and tighten using the Nut and washers from inside the chassis.
13. Now you can place the cylinder is approx. 200mm from the ground.
14. Hold cylinder and align holes. Insert two ½" bolts through the top two holes, these will screw into the rivert on mounting bracket. Then insert the bottom two ½" bolts and tighten using the Nut and washers from behind the bracket.
15. Once this has been achieved you can now install the foot plate to the underside of cylinder using the ¾" locking nut.
16. **IMPORTANT!!** When tighten the foot plate to cylinder ensure to only use a rattle gun or impact wrench.





Ready for deployment



REDFOOT Keypad Recommendation



The ideal location for the keypad is near the entrance inside the vehicle. For ease of use, mount the keypad on the side as you enter the motorhome so when you are facing the keypad you are facing forward in the vehicle. (Like you are driving the vehicle)

This position will allow you to operate from either inside or outside the vehicle. Allow enough space behind the keypad panel to give good access to harness connection plugs.

You will require a Cutting Router to cut a hole in the wall and Power Drill to screw and affix the keypad to the wall.

REDFOOT Pump/Manifold Locations



The ideal location for the Pump/Manifold can be inside E.g Storage compartment or outside the vehicle as shown. The important thing is to have ease of access in the case of a 'manual override' to retract all cylinders. This can only happen if you lose all power to the system and you need to move on from your site.

There are two access points you need in a manual override situation; access to front of motor and access to the four valves on the side of pump. See the picture directly above with the arrows pointing to these. For more information on this process read the manual override section in your user manual.

If you decide to install the Pump/Manifold to the underneath of the vehicle please ensure you install a protection cover to prevent objects hitting the unit or reservoir, potentially damaging the system.

REDFOOT Operational



For further information contact:
Redfoot Levelling Pty Ltd
Unit 1, 7 Abeles Street
Baringa QLD 4551 5
Ph 07 5228 0211
www.redfootlevelling.com.au